

ATTAIN ABILITY™ MRI SURESCAN™ MODEL 4196

Steroid eluting, dual electrode, transvenous,
over the wire, cardiac vein pacing lead

Product specifications

Physical characteristics

Type	Dual electrode
Chamber paced	Left ventricle
Length	78 and 88 cm (30.71 and 34.65 in)
Connector	IS-1 BI
Material	
Conductor	SI-PI coated 25% Ag-core-MP35N
Insulators	Polyurethane (outer) SI-polyimide (SI-PI) (inner) ^a
Ring electrode	Platinum iridium alloy with titanium nitride coating
Tip electrode	Platinum iridium alloy with titanium nitride coating
Connector pin	Stainless steel
Connector ring	Stainless steel
Molded tip seal	Silicone rubber (with steroid)
Tip electrode configuration	Tapered, annular, titanium- nitride-coated, steroid-eluting
Ring electrode configuration	Radiused, titanium-nitride- coated, steroid eluting
Diameter	
Lead body	1.3 mm (4 French)
Tip electrode	1.53 mm (4.6 French)
Ring electrode	1.70 mm (5.1 French)
Medtronic delivery system (recommended inner diameter)	1.90 mm (5.7 French)
Diagnostic guide wire (recommended diameter)	0.36 mm to 0.46 mm (0.014 in to 0.018 in)
Electrode surface area	
Tip	5.8 mm ²
Ring	5.8 mm ²
Conductor resistance	
Tip	38 ± 10 Ω (78 cm) 43 ± 10 Ω (88 cm)
Ring	35 ± 10 Ω (78 cm) 40 ± 10 Ω (88 cm)
Distance between electrodes	21 mm
Steroid	Dexamethasone acetate
Target dose of steroid	160 µg at tip MCRD ^b 72 µg at ring MCRD 232 µg target combined amount

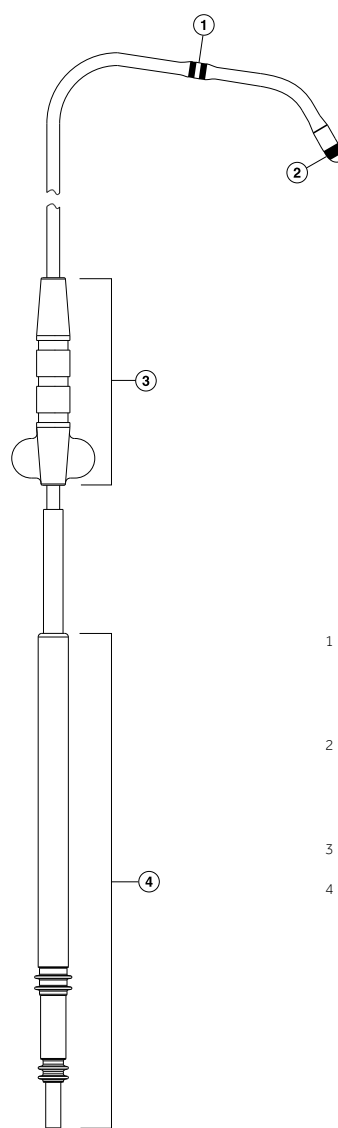

¹ Proximal electrode: nominally
5.8 mm² geometric pacing
surface area

² Tip electrode: nominally
5.8 mm² geometric pacing
surface area

³ Anchoring sleeve

⁴ IS-1 BI connector

^a Technology developed by NASA.

^b Monolithic controlled release device

Brief Statement

Attain Ability™ and Attain™ Performa™ MRI SureScan™ Leads

Indications

The Attain Ability 4196, 4296, and 4396 steroid eluting, dual electrode, IS-1 transvenous leads are indicated for chronic pacing and sensing in the left ventricle via the cardiac vein, when used in conjunction with a compatible Medtronic Cardiac Resynchronization Therapy (CRT) system. Extended bipolar pacing is available using these leads in combination with a compatible CRT-D system and RV defibrillation lead or with a compatible CRT-P system* and RV pacing lead. Unipolar pacing is available using the leads in combination with a compatible CRT-P system.

The Attain Performa 4298, 4398, 4598 steroid eluting, quadripolar electrode, IS4 transvenous leads are indicated for chronic pacing and sensing in the left ventricle via the cardiac vein, when used with a compatible Medtronic Cardiac Resynchronization Therapy (CRT) system. Extended bipolar pacing is available using this lead in combination with a compatible CRT-D system and RV defibrillation lead.

The Attain Ability MRI SureScan and Attain Performa MRI SureScan Leads are part of the Medtronic SureScan Implantable Cardioverter Defibrillator with Cardiac Resynchronization (CRT-D) system. A complete SureScan CRT-D system is required for use in the MR environment and includes a Medtronic SureScan device connected to Medtronic SureScan leads.

Contraindications

The Attain Ability leads are contraindicated for the following:

Coronary vasculature—These leads are contraindicated for patients with coronary venous vasculature that is inadequate for lead placement, as indicated by venogram.

Steroid use—Do not use in patients for whom a single dose of 232 µg of dexamethasone acetate cannot be tolerated.

The Attain Performa leads are contraindicated for the following:

Coronary vasculature—These leads are contraindicated for patients with coronary venous vasculature that is inadequate for lead placement, as indicated by venogram.

Steroid use—Do not use in patients for whom a single dose of 288 µg of dexamethasone acetate may be contraindicated.

Warnings and Precautions

Diathermy is a treatment that involves the therapeutic heating of body tissues. Diathermy treatments include high frequency, short wave, microwave, and therapeutic ultrasound. Except for therapeutic ultrasound, do not use diathermy treatments on cardiac device patients. Diathermy treatments may result in serious injury or damage to an implanted device and lead system. Therapeutic ultrasound (including physiotherapy, high intensity therapeutic ultrasound, and high intensity focused ultrasound), is the use of ultrasound at higher energies than diagnostic ultrasound to bring heat or agitation into the body. Therapeutic ultrasound is acceptable if treatment is performed with a minimum separation distance of 15 cm (6 in) between the applicator and the implanted device and lead system, as long as the ultrasonic beam is pointing away from the device and lead system.

* Medtronic does not currently market any MR-Conditional CRT-P devices.

A complete SureScan CRT-D system is required for use in the MR environment. Before performing an MRI scan, refer to the SureScan MRI Technical Manual for important information about procedures and MRI-specific warnings and precautions. Patients and their implanted systems must be screened to meet the following requirements for MRI: no implanted lead extenders, lead adaptors, or abandoned leads; for patients with multiple MR-Conditional devices present, the MR labeling conditions for all implants are satisfied; no broken leads or leads with intermittent electrical contact as confirmed by lead impedance history; the SureScan CRT-D system is implanted in the left or right pectoral region; the CRT-D device is operating within the projected service life; no diaphragmatic stimulation at a pacing output of 5.0 V and at a pulse width of 1.0 ms in patients whose device will be programmed to an asynchronous pacing mode when MRI SureScan is programmed to On. For pacemaker-dependent patients, it is not recommended to perform an MRI scan if the right ventricular (RV) lead pacing capture threshold is greater than 2.0 V at 0.4 ms. A higher pacing capture threshold may indicate an issue with the implanted lead.

Patients may be scanned using a horizontal field, cylindrical bore, clinical 1.5T MRI system with operating frequency of 64 MHz, maximum spatial gradient ≤ 20 T/m, and maximum gradient slew rate performance per axis ≤ 200 T/m/s. Scanner must be operated in Normal Operating Mode (whole body averaged specific absorption rate (SAR) ≤ 2.0 W/kg, head SAR ≤ 3.2 W/kg).

The Model 4196, 4296, and 4396 leads were designed for optimal pacing when used in a unipolar or extended bipolar configuration. The standard bipolar configuration may result in markedly elevated pacing thresholds or produce anodal stimulation.

Potential Complications

Potential complications related to the use of transvenous leads include, but are not limited to, the following patient-related conditions: air embolism; avulsion or other damage to the endocardium, valve, or vein (particularly in fragile hearts); cardiac dissection; cardiac perforation; cardiac tamponade; coronary sinus dissection; death; endocarditis; erosion through the skin; extracardiac muscle or nerve stimulation; fibrillation or other arrhythmias; heart block; heart wall or vein wall rupture; hematoma/seroma; infection; lead conductor fracture or insulation failure; lead dislodgement; myocardial irritability; myopotential sensing; pericardial effusion; pericardial rub; pericarditis; pneumothorax; rejection phenomena (local tissue reaction, fibrotic tissue formation); threshold elevation or exit block; thrombosis; thrombotic embolism.

The SureScan CRT-D system has been designed to minimize potential complications in the MRI environment. Potential MRI complications include, but are not limited to, lead electrode heating and tissue damage resulting in loss of sensing or capture or both, or induced currents on leads resulting in continuous capture, VT/VF, and/or hemodynamic collapse.

See the MRI SureScan Technical Manual before performing an MRI Scan and Device Manual for detailed information regarding the implant procedure, indications, contraindications, warnings, precautions, and potential complications/adverse events. For further information, please call Medtronic at 1 (800) 328-2518 and/or consult Medtronic's website at www.medtronic.com or www.mrisurescan.com.

Caution: Federal law (USA) restricts this device to sale by or on the order of a physician.

Medtronic
710 Medtronic Parkway
Minneapolis, MN 55432-5604
USA
Tel: (763) 514-4000
Fax: (763) 514-4879

Toll-free: 1 (800) 328-2518
(24-hour technical support for
physicians and medical professionals)

UC201602588 EN © Medtronic 2015.
Minneapolis, MN. All Rights Reserved.
Printed in USA. 11/2015